

UM10417

Demo board for mains 17 W LED driver and dimmer using the SSL2102

Rev. 1 — 30 September 2010

User manual

Document information

Info	Content
Keywords	SSL2102, AC mains supply, dimmable LED driver, AC/DC conversion
Abstract	This User manual describes a demonstration (demo) board for evaluating an AC mains LED driver with a dimmer for 17 W, PAR38 LEDs using the SSL2102. It also describes key features and connections to aid the design of LED drivers for typical applications.



Revision history

Rev	Date	Description
1	20100930	Initial version

Contact information

For more information, please visit: <http://www.nxp.com>

For sales office addresses, please send an email to: salesaddresses@nxp.com

1. Introduction

This User manual describes a demonstration (demo) board for evaluating an AC mains LED driver with a dimmer for 17 W, PAR38 LEDs using the SSL2102. It describes key features and connections to aid the design of LED drivers for typical applications.

The demo board operates from an AC mains voltage of 120 V AC (60 Hz). The resulting design is a trade-off between high power factor, efficiency and dimmer compatibility, combined with high output stability and ElectroMagnetic Compliance (EMC) compliance.

WARNING

Lethal voltage and fire ignition hazard



The non-insulated high voltages that are present when operating this product, constitute a risk of electric shock, personal injury, death and/or ignition of fire.

This product is intended for evaluation purposes only. It shall be operated in a designated test area by personnel qualified according to local requirements and labor laws to work with non-insulated mains voltages and high-voltage circuits. This product shall never be operated unattended.

The demo board is powered by AC mains voltage. Avoid touching the board when power is applied. An isolated housing is obligatory when used in uncontrolled, non-laboratory environments.

The secondary circuit with LED connection has galvanic isolation, however this isolation is not in accordance with any standard and has not been thoroughly tested. Thus it is recommended to always provide galvanic isolation of the mains phase using a variable transformer. Isolated and non-isolated devices are identified by the following symbols.

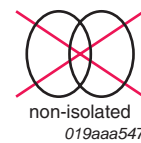
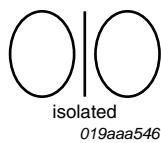

a. Isolated

b. Non-isolated

Fig 1. Isolated and non-isolated symbols

2. Specification

Table 1. Demo board specification

Parameter	Value	Comment
AC line input voltage	0 V to 150 V AC, 60 Hz	120 V AC model
Output voltage (LED voltage)	17 V to 33 V DC	
Output voltage protection	33 V DC	
Output current (LED current)	600 mA typical	
Input voltage/load current dependency	-2.7 % to +3.2 %, input voltage from 110 V to 150 V AC	see Figure 7 on page 14
Output voltage/load current dependency	-8.9 % to +9.1 %, output voltage from 19 V to 30 V DC	see Figure 7 on page 14
Temperature stability	-1.9 % to +2.4 % from 100 °C to -20 °C; acceleration life test of IC over 75,000 hours	
Current ripple	±15 % at 550 mA	typical value
Maximum output power (LED power)	19 W	depends on load
Efficiency	76 % to 82 %	at T _{amb} = 25 °C, depends on output load and input voltage; see Figure 10 on page 18 and Figure 11 on page 18
Power factor at input voltage of 120 V AC	>0.95	see Figure 12 on page 19
Switching frequency	40 kHz to 60 kHz	at 120 V AC input voltage
Dimming range	100 % to 0 %	for triac dimmer
Board dimensions	82 mm × 62 mm × 35 mm	LXBXH
Operating temperature	0 °C to 105 °C	
EMC Compliance	FCC15 and IEC 61000-3-2 pre-compliant EN 55015 and IEC 61000-3-2 pre-compliant	at 120 V AC input voltage; see Figure 13 on page 20 and Figure 14 on page 20

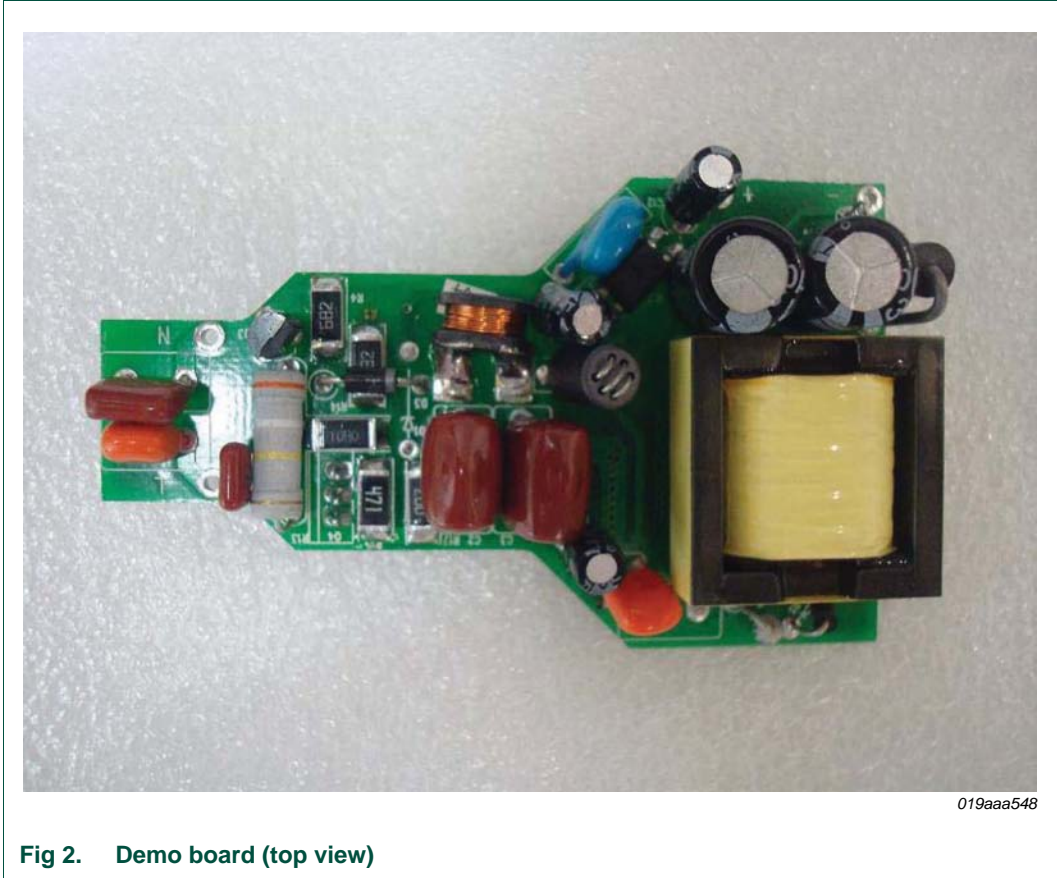

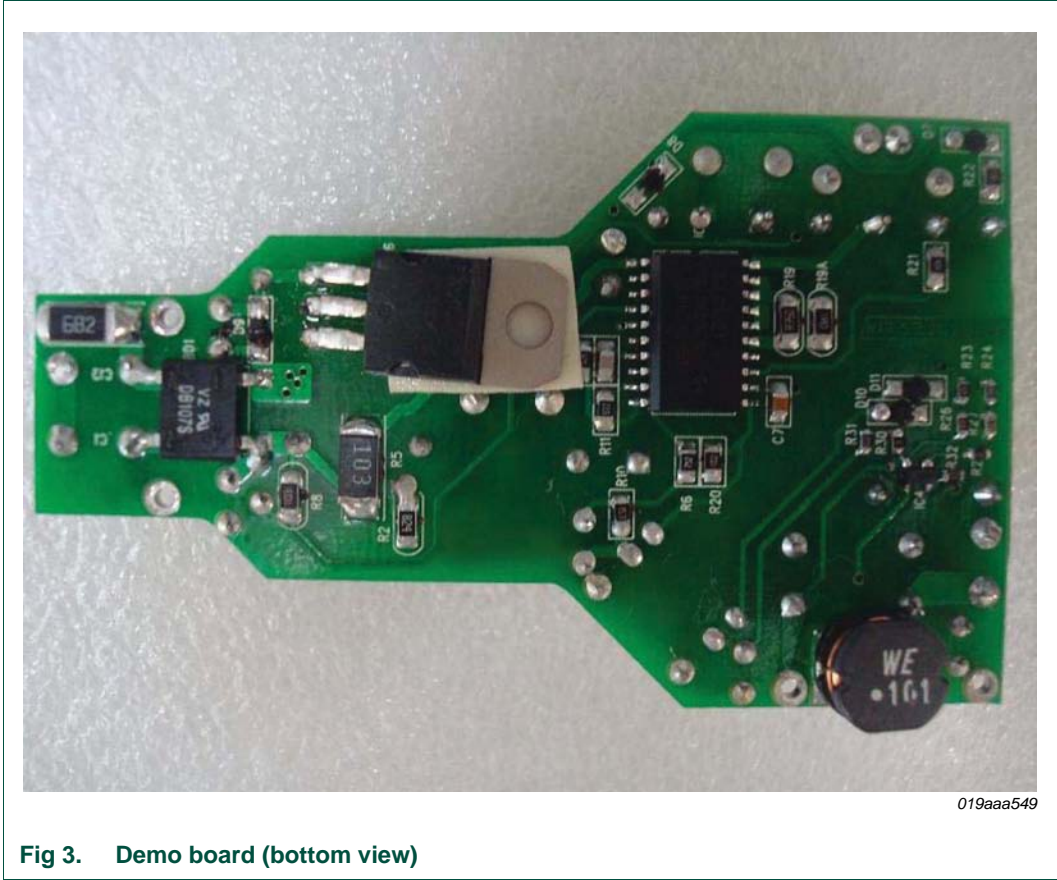

3. Demo board connections

The demo board is optimized for an AC mains source of 120 V (60 Hz). It is designed to work with multiple high power LEDs having a total working voltage of between 18 V and 33 V. The output current is set to 600 mA at typical load. The output voltage is limited to 33 V.

When attaching a LED load to an operational board (hot plugging) an inrush peak current will occur due to the discharge of output capacitors C9 and C10. Note that frequent discharges may damage or deteriorate the LEDs.

Remark: It is recommended to mount the board in a shielded or isolated box for demonstration purposes.

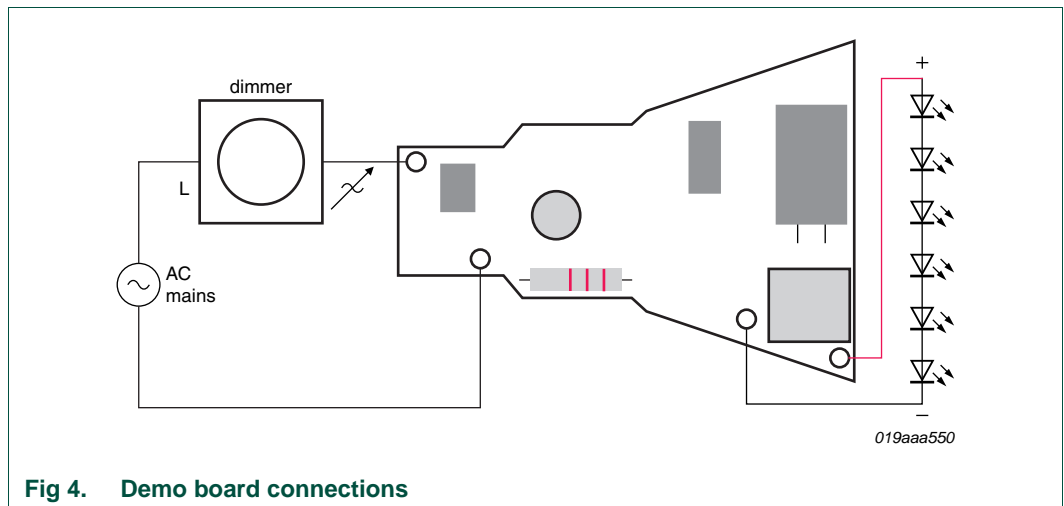

Fig 4. Demo board connections

If a galvanic isolated transformer is used, this should be placed between the AC source and the demo board. Connect a series of between 5 and 10 LEDs to the output as shown in [Figure 4](#).

4. Dimmers

NXP Semiconductors has tested the performance of several triac-based dimmers having different specifications. The range of dimmers which have been tested with the demo board are given in [Table 2](#).

Table 2. Tested dimmers
An incandescent lamp is used as load.

Manufacturer	Type	AC Voltage (V)	Power range (W)	Low dim level (%)
Lutron	TG-600PH-WH	120	600	0
Levitron	L12-6641-W	120	600	0
Levitron	L02-700-W	120	600	0
Levitron	6602-IW	120	600	0
Levitron	6683-W	120	600	0
Levitron	R12-6631-LW	120	600	0
Cooper	6001	120	600	0
Lutron	S-600PH	120	600	0
GE	18019	120	600	0
GE	18025	120	600	0
GE	52129	120	600	0

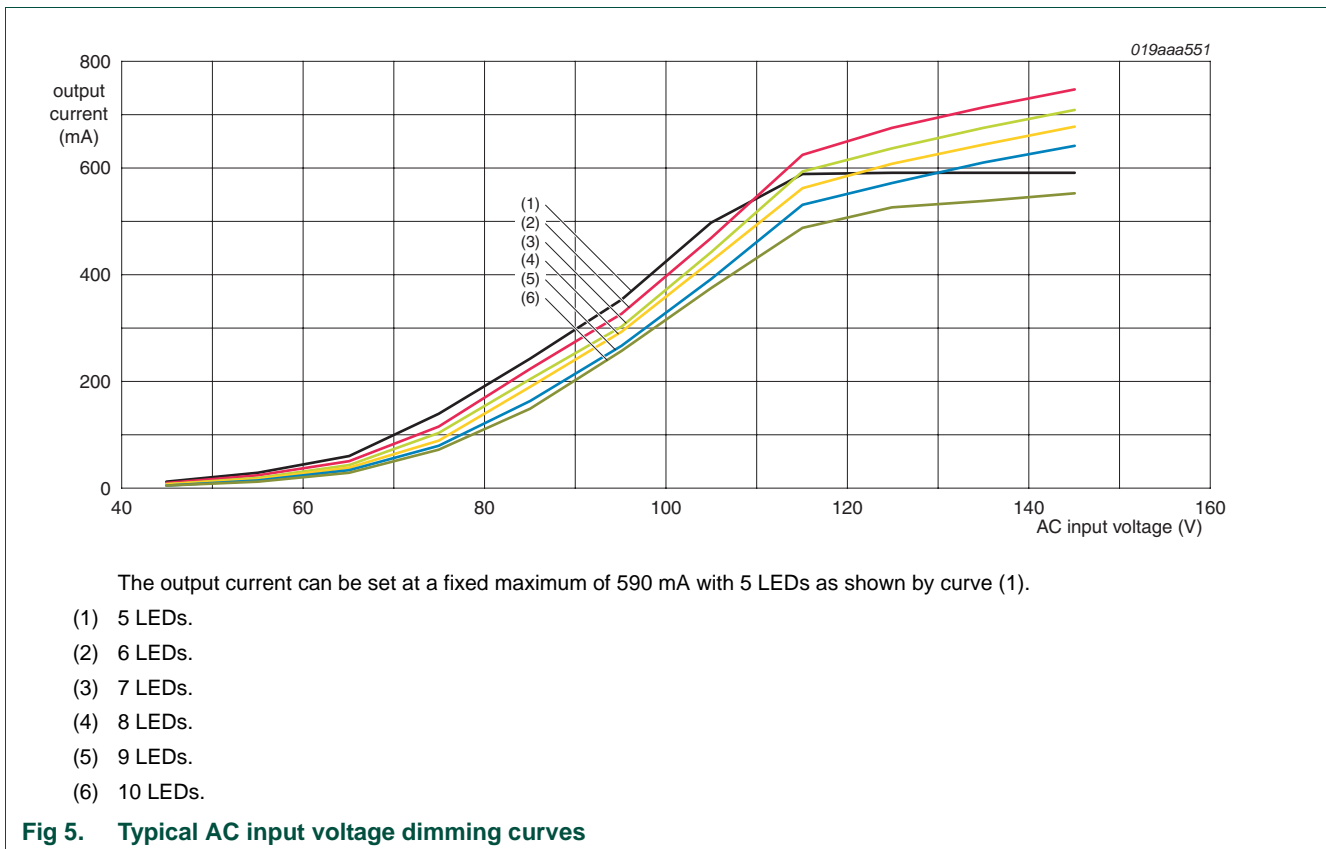

5. Functional description

Refer to [Figure 7 “Demo board 120 V AC schematic” on page 14](#). The AC mains LED driver IC SSL2102 controls and drives a flyback converter circuit and ensures correct dimmer operation. The IC has three integrated high voltage switches, one of which, located between pins DRAIN and SOURCE, controls flyback input power. When the switch opens, a current flows which is stored as energy in transformer TX1. This current is interrupted, either when the duty factor exceeds the 75 % maximum level set by pin PWMLIMIT, or when the voltage on pin SOURCE exceeds 0.5 V. In the next cycle, the energy stored in the transformer discharges via D6 to output capacitors C9 and C10 and finally absorbed by the load. The flyback converter frequency is set by an internal oscillator whose timing is controlled by external RC components connected to pins RC and RC2. The frequency can be set by pin BRIGHTNESS to an upper or a lower value. The flyback converter frequency range is set by the ratio between R11 and R12.

The two other switches in the IC are called weak-bleeder (pin WBLEED) and strong-bleeder (pin SBLEED). When the voltage on both these pins is below a certain value, typically 52 V, the strong-bleeder switches on to provide a path for load current to the dimmer during zero voltage crossing, resetting the dimmer timer. When the voltage on both pins is above 52 V and the voltage on pin ISENSE is above -100 mV, the weak-bleeder is switched on by transistor Q3. This supplies a boosted (hold) current to the dimmer to maintain stable latching during the periods when the flyback converter draws insufficient current.

[Figure 6](#) shows the bleeder voltage against time in dimmed and undimmed modes.

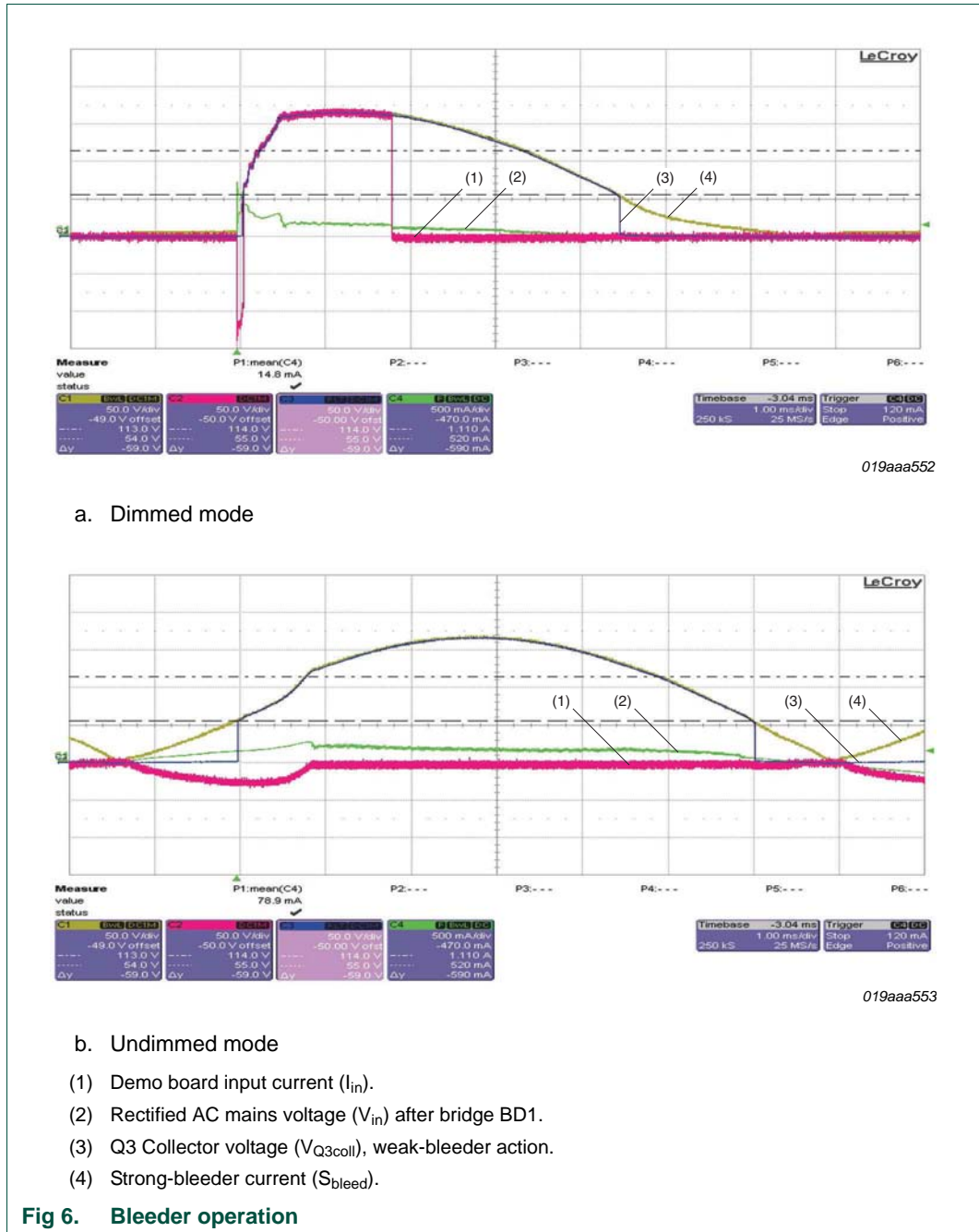

The demo board is optimized to work at a power factor above 0.9. In order to achieve this, the flyback converter operates during the MOSFET on-time. The output power of the flyback converter is buffered by capacitors C9 and C10. This configuration gives the circuit a resistive input current behavior in undimmed mode; see curve I_{in} in [Figure 6](#).

In dimmed mode, the dimmer latch and hold current must be maintained and a damper must be added to dampen the inrush current and dissipate the electric power stored in the dimmer's LC filter. A serial resistor can be used as a damper at power ranges of less than 10 W, this however, is inefficient at higher power ranges due to the significant voltage drop and dissipation that will occur from the supply current to the flyback converter.

Darlington transistor Q4 provides the necessary high gain and will be in saturation as long as its base voltage is above the emitter voltage plus the base-emitter voltage (V_{BE}). The voltage across emitter resistor R14 increases with the current. When the emitter voltage rises above the threshold, Q4 stops saturation, turns off, and the current is then limited by R15. The values of D9 and R13 affect efficiency and power factor and must be chosen with care to ensure consistent operation over the input voltage range from 120 V to 230 V AC.

A combination of serial resistance and a parallel damper is chosen. The serial resistance comprises R14, R15 and R17. The parallel group damper comprises C1, C13 and R1 in parallel with C8 and R7 for optional fine tuning. To improve efficiency, the major serial damping is activated only when there is a peak inrush current (active inrush current limiter). In normal operation, Darlington transistor Q4 conducts, bypassing R15 and lowering ohmic losses. When a high inrush current is detected, Q4 starts to clip at its maximum current of 600 mA.

The flyback converter input circuit must have a filter that is partially capacitive. C2, L2, C3, C13 and L1 form a filter that blocks most of the disturbance generated by the flyback converter input current. The drawback of this filter is a reduced power factor due to the capacitive load. A lower flyback converter power relative to the capacitive value of this filter/buffer reduces the power factor. With the 120 V AC design using 330 nF capacitors, a minimum power factor of 0.98 is achieved.

The demo board has a feedback loop to limit the output current. The feedback loop senses the LED current through sense resistor R25, and current mirror circuit with IC4. The current level can be set using R27 and R29. The same feedback loop is also used for overvoltage protection. If the LED voltage exceeds 36 V, a current starts to flow through R23 and D11. The current through the optocoupler IC3 forces pins PWMLIMIT and BRIGHTNESS LOW. At a value below 400 mV, the MOSFET on-time is zero.

The feedback loop has proportional action only, and the gain is critical because of phase shift caused by the flyback converter and C6.

The relationship between pin PWMLIMIT and the output current is quadratic in nature. The resulting output current spread will be acceptable for most LED applications. If higher demands are placed on LED current spread, a secondary regulation circuit in combination with an added pure current action control is advisable.

The dimming range is detected by sensing the average rectified voltage. R2 and R10 form a voltage divider, and C4 filters the resulting signal. The flyback converter sets its duty factor and converter frequency accordingly.

6. System optimization

The modifications described in this section can be applied to achieve customer application specifications.

6.1 Changing output voltage and LED current

One of the major advantages of a flyback converter over other topologies is its suitability for driving different output voltages. In essence, changing the winding ratio whilst maintaining the value of the primary inductance will shift the output working voltage accordingly. Part of the efficiency of the driver is linked to the output voltage. A lower output voltage will increase transformation ratio and cause higher secondary losses. In practice, a mains dimmable flyback converter will have an efficiency of between 85 % for higher output power and voltage such as 60 V, down to 60 % for lower output power and voltage such as 1 W and 3 V respectively. At lower voltages, synchronous rectification may be advisable to reduce losses after high current is rectified; synchronous rectification controllers TEA1761 and TEA1791 from NXP Semiconductors can be used for this purpose. Calculations for transformer properties and peak current are described in detail in application note *AN10754, SSL2101 and SSL2102 dimmable mains LED driver*. The output voltage protection is set by the value of D11. Changing the value of D11 allows the the LED driver to be adapted to a specific output load and to reduce the load's hot swap inrush current.

6.2 Changing the output ripple current

The output ripple current is mainly determined by the LED voltage, the LED dynamic resistance and the output capacitor. Whilst the values of C9 and C10 are chosen to optimize capacitor size with LED brightness. A ripple of $\pm 15\%$ will result in an expected deterioration of LED brightness of less than 1 %¹.

The size of the buffer capacitor can be determined from [Equation 1](#).

$$\left(C10 + C9 = \frac{I_{led}}{\Delta I} \right) \times \frac{1}{6 \times f_{net} \times R_{dynamic}} \quad (1)$$

Example: with a ripple current of $\pm 5\%$, AC mains frequency of 50 Hz, and a dynamic resistance of 0.6Ω , the resultant value of C9 + C10 is $\frac{20}{300 \times 0.6} = 111 \mu\text{F}$.

With a ripple current of 25 % and a dynamic resistance of 6Ω , the resultant value of C9 + C10 is $\frac{4}{300 \times 6} = 2200 \mu\text{F}$.

Using a series of LEDs, the dynamic resistance of each LED can be added to the total dynamic resistance.

1. M. Weiland 28-07-2006

6.3 Adapting to high power reverse phase (transistor) dimmers

Reverse phase (transistor) dimmers differ in two ways that can be beneficial:

- Because of the negative phase, there is no inrush current when the dimmer triggers. With triac dimmers, there is a sudden voltage difference over the input, resulting in a steep charge of the input capacitors. The resulting peak current results in higher damper dissipation. With transistor dimmers, this steep charge is missing, the input capacitors will have less stress and the input circuit is less prone to audible noise.
- Transistor dimmers contain active circuitry that require a load charge during the time that the dimmer is open. The dimensioning of the circuit generating the internal supply voltage inside the dimmer is made critical in order to avoid internal dimmer losses. This means that the remaining voltage drop across the lamp must be low enough to allow this charge to be reached. The minimum load to achieve such a voltage drop would result in very inefficient operation at low output power levels since most of the energy is wasted driving the dimmer instead of producing light.

On the demo board, the weak-bleeder resistor values of R3 and R4 are chosen so that losses are within acceptable limits and only occur in dimmed mode at the end of the phase. The voltage drop in some transistor dimmers is however not sufficient to allow full control of the dimming range, whereas the SSL2102 senses the dimming range by taking the average rectified voltage as input. To compensate for the reduced voltage difference, the voltage detection can be made more sensitive by placing a Zener diode in series with R2. Because of increased sensitivity, the dimming curve will be steeper and shifted when using triac dimmers.

6.4 Changing the output current

The output current can be set initially by varying the values of R29 and R27. The power section and transformer train can withstand output currents up to 700 mA, but losses will increase with higher current levels. Note that resistors R19A/B limit the primary peak current and thus the maximum output power.

7. Demo board schematic

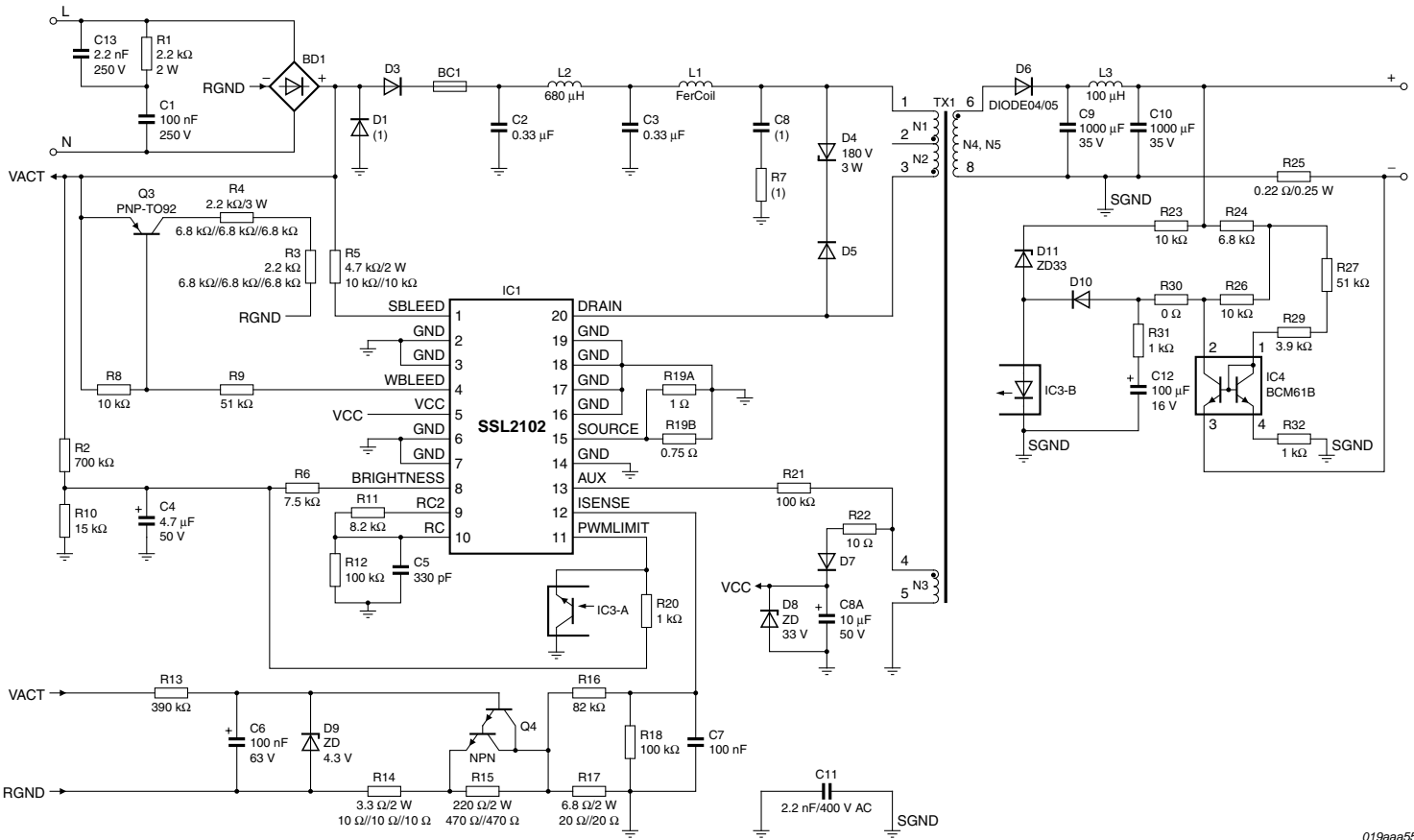

019aaa554

(1) Optional.
Some resistor values are shown with format x/x/x which represent the values required of resistors connected in parallel.

Fig 7. Demo board 120 V AC schematic

8. PCB components

Table 3. Demo board 120 V AC components

Designator	Description	Part identifier	Manufacturer
R1	2.2 k Ω , 2 W, 5 %, 200 V, SMD, 2512	-	-
R2	700 k Ω , 0.25 W, 1 %, 200 V, SMD, 1206	-	-
R3, R4	2.2 k Ω , 3 W, 5 %, 400 V, SMD, 2512	-	-
R5	4.7 k Ω , 2 W, 5 %, 400 V, SMD, 2512	-	-
R6	7.5 k Ω , 0.125 W, 5 %, SMD, 0805	-	-
R8	10 k Ω , 0.125 W, 5 %, SMD, 0805	-	-
R9	51 k Ω , 0.25 W, 5 %, 200 V, SMD, 1206	-	-
R10	15 k Ω , 0.125 W, 1 %, SMD, 0805	-	-
R11	8.2 k Ω , 0.125 W, 1 %, SMD, 0805	-	-
R12, R18	100 k Ω , 0.125 W, 1 %, SMD, 0805	-	-
R13	390 k Ω , 2 W, 5 %, DIP	-	-
R14	3.3 Ω , 3 W, 5 %, 400 V, SMD, 2512	-	-
R15	220 Ω , 2 W, 5 %, 400 V, SMD, 2512	-	-
R16	82 k Ω , 0.125 W, 1 %, SMD, 0805	-	-
R17	6.8 Ω , 2 W, 5 %, 400 V, SMD, 2512	-	-
R18	100 k Ω , 0.125 W, 1 %, SMD, 0805	-	-
R19A	1 Ω , 0.25 W, 1 %, SMD, 1206	-	-
R19B	0.75 Ω , 0.25 W, 1 %, SMD, 1206	-	-
R20	1 k Ω , 0.125 W, 1 %, SMD, 0805	-	-
R21	100 k Ω , 0.125 W, 5 %, SMD, 0805	-	-
R22	10 Ω , 0.125 W, 5 %, SMD, 0805	-	-
R23	10 k Ω , 0.125 W, 5 %, SMD, 0603	-	-
R24	6.8 k Ω , 0.125 W, 5 %, SMD, 0603	-	-
R25	0.22 Ω , 0.25 W, 1 % DIP	-	-
R26	10 k Ω , 0.125 W, 1 %, SMD, 0603	-	-
R27	51 k Ω , 0.125 W, 1 %, SMD, 0603	-	-
R29	3.9 k Ω , 0.125 W, 1 %, SMD, 0603	-	-
R30	0 Ω , 0.125 W, 5 %, SMD, 0603	-	-
R31	1 k Ω , 0.125 W, 5 %, SMD, 0603	-	-
R32	1 k Ω , 0.125 W, 1%, SMD, 0603	-	-
C1	100 nF, MKT, 10 %, 400 V	-	-
C2, C3	330 nF, MKT, 10 %, 400 V	-	-
C4	4.7 μ F, 105 $^{\circ}$ C, 10 %, 50 V	-	-
C5	330 pF, Cer, 10 %, 50 V, SMD, 0603	-	-
C6	100 nF, MKT, 10 %, 63 V	-	-
C7	100 nF, Cer, 10 %, 50 V, SMD	-	-
C8A	10 μ F, 105 $^{\circ}$ C, 10 %, 50 V	-	-
C9, C10	1000 μ F, 105 $^{\circ}$ C, 20 %, 35 V	MCRH35V108, M13X21	Multicomp
C11	2.2 nF, Y, 20 %, 400 V	-	-

Table 3. Demo board 120 V AC components ...continued

Designator	Description	Part identifier	Manufacturer
C12	100 μ F, 105 $^{\circ}$ C, 20 %, 16 V	-	-
C13	2.2 nF, MKT, 10 %, 250 V	-	-
L2	680 μ H, 10 %, SMD, WE-PD2	744776268	Würth
L3	100 μ H, 10 %, SMD, WE-PD	74477720	Würth
TX1	transformer, 1m, E25-25-8	750340772	WE-Midcom
BD1	rectifier bridge, SMD, DB107S	-	-
D1	TVS diode, P6KE250 (optional)	-	-
D3	diode, HER107	-	-
D4	Zener, 3 W, 180 V, BZT03C180	-	-
D5	diode, HER107	-	-
D6	diode, HER303	-	-
D7	diode, SMD, BAS16J	-	NXP
D8	Zener, 33 V, SMD, SOD66, BZX84J-B33	-	NXP
D9	Zener, 4.3 V, SMD, SOD80C, BZX84J-B4V3	-	NXP
D10	diode, SMD, BAS16J	-	NXP
D11	Zener, 33 V, SMD, SOD66, BZX84J-B33	-	NXP
Q3	transistor, PNP, TO-92, MPSA92	-	-
Q4	transistor, NPN, TO-220, ST901T	-	-
IC1	controller, SMD, SOW-20, SSL2102	SSL2102	NXP
IC3	optocoupler, SMD, SO-4, PC817	PC817	-
IC4	dual, NPN, SMD, SOT143B, BCM61B	BCM61B	NXP

9. Test results

9.1 Input/output stability

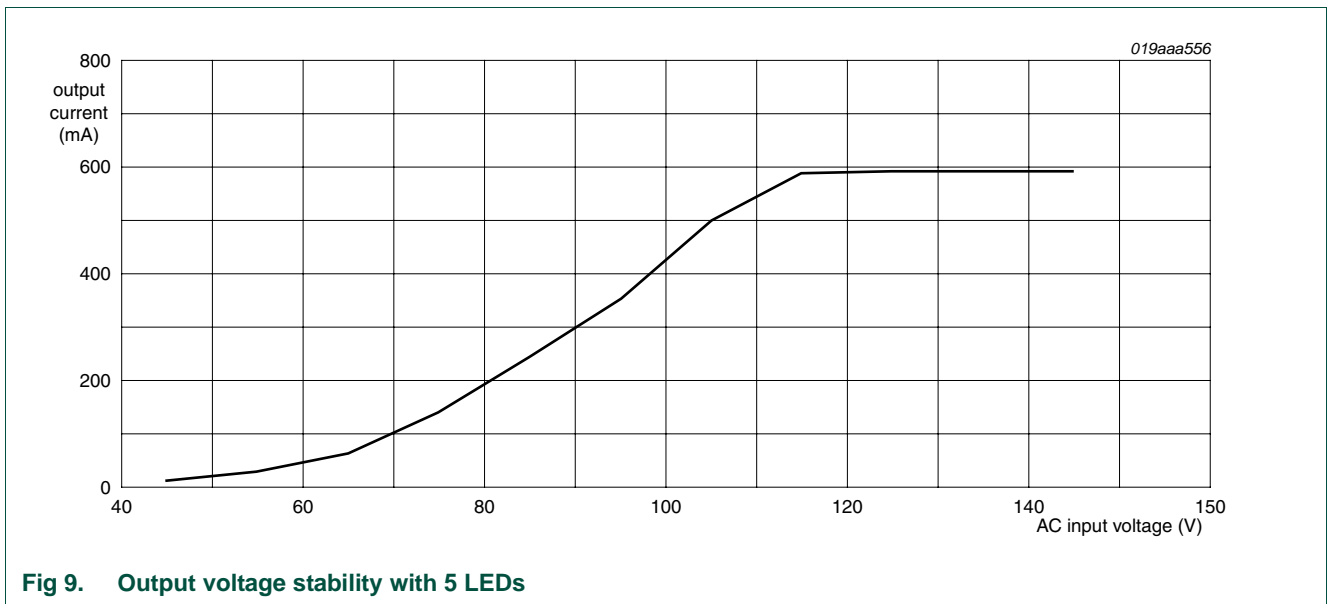
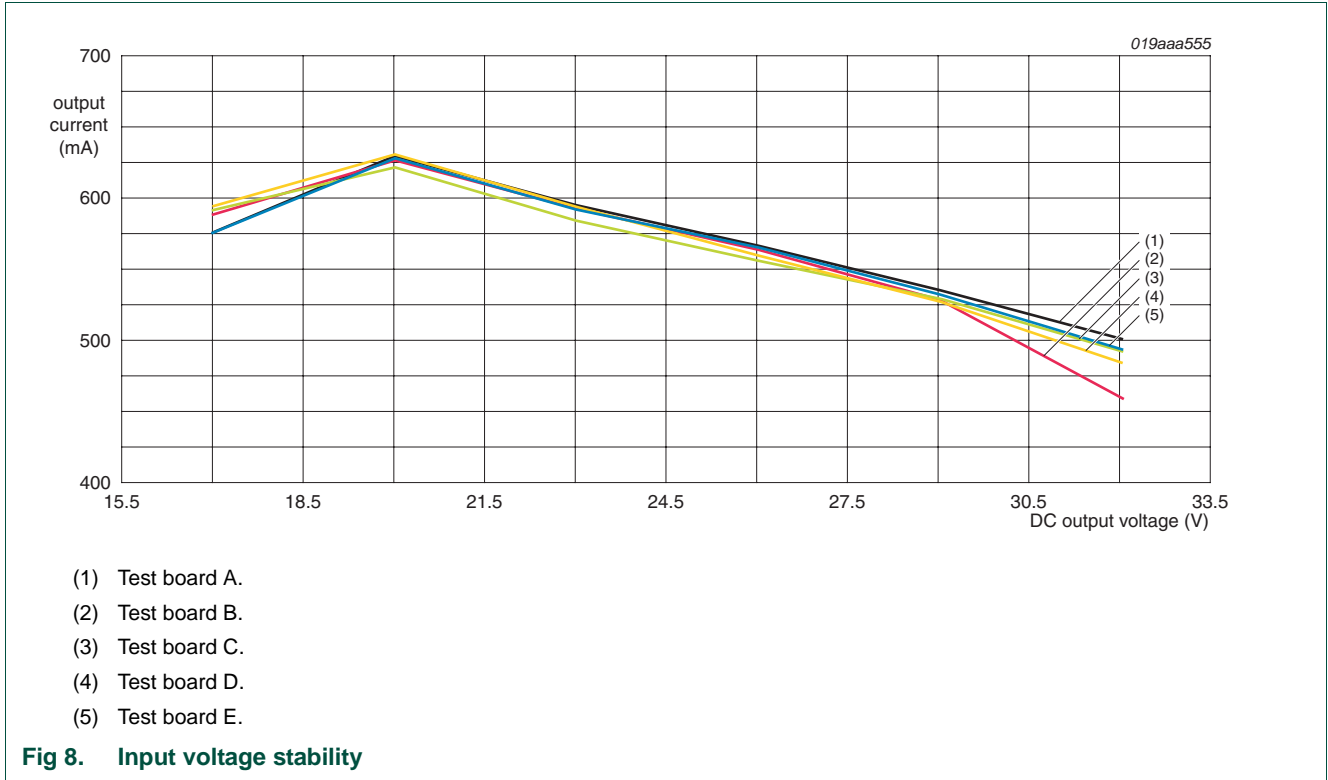

9.2 Efficiency graphs

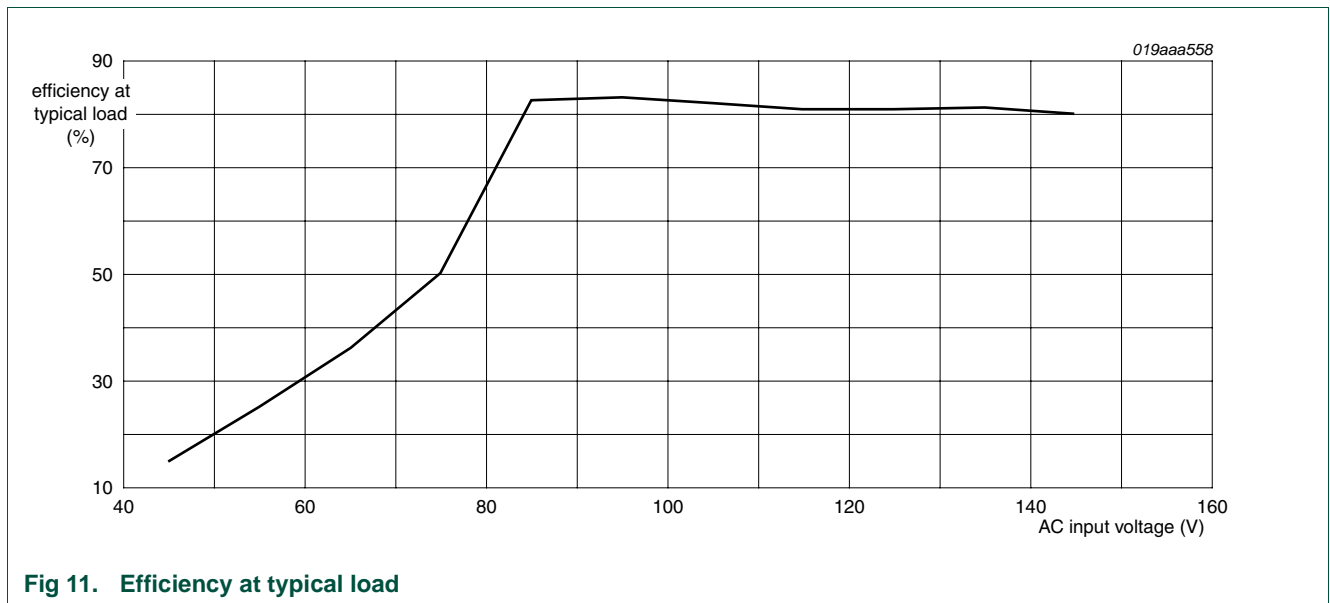
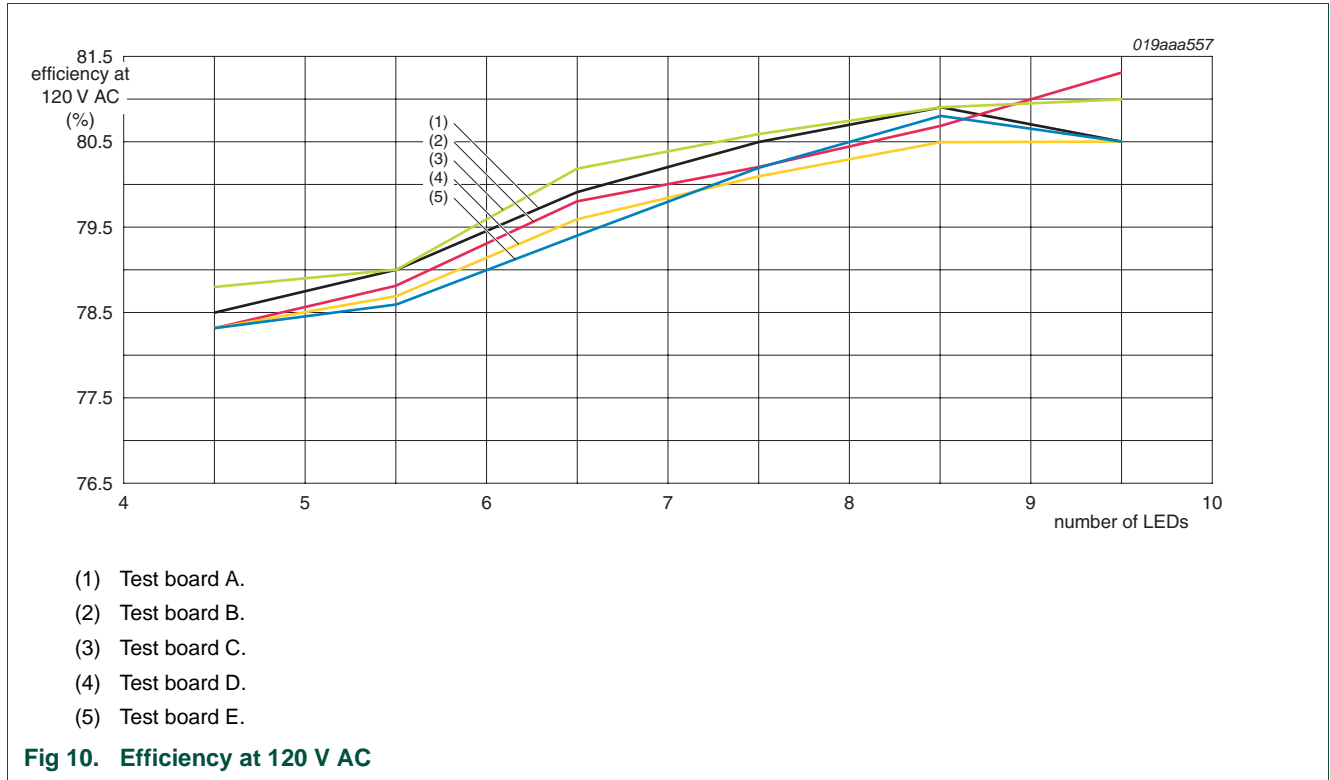

9.3 Temperature stability

The temperature stability depends on the LED heatsink and the lamp's form factor.

9.4 Power factor

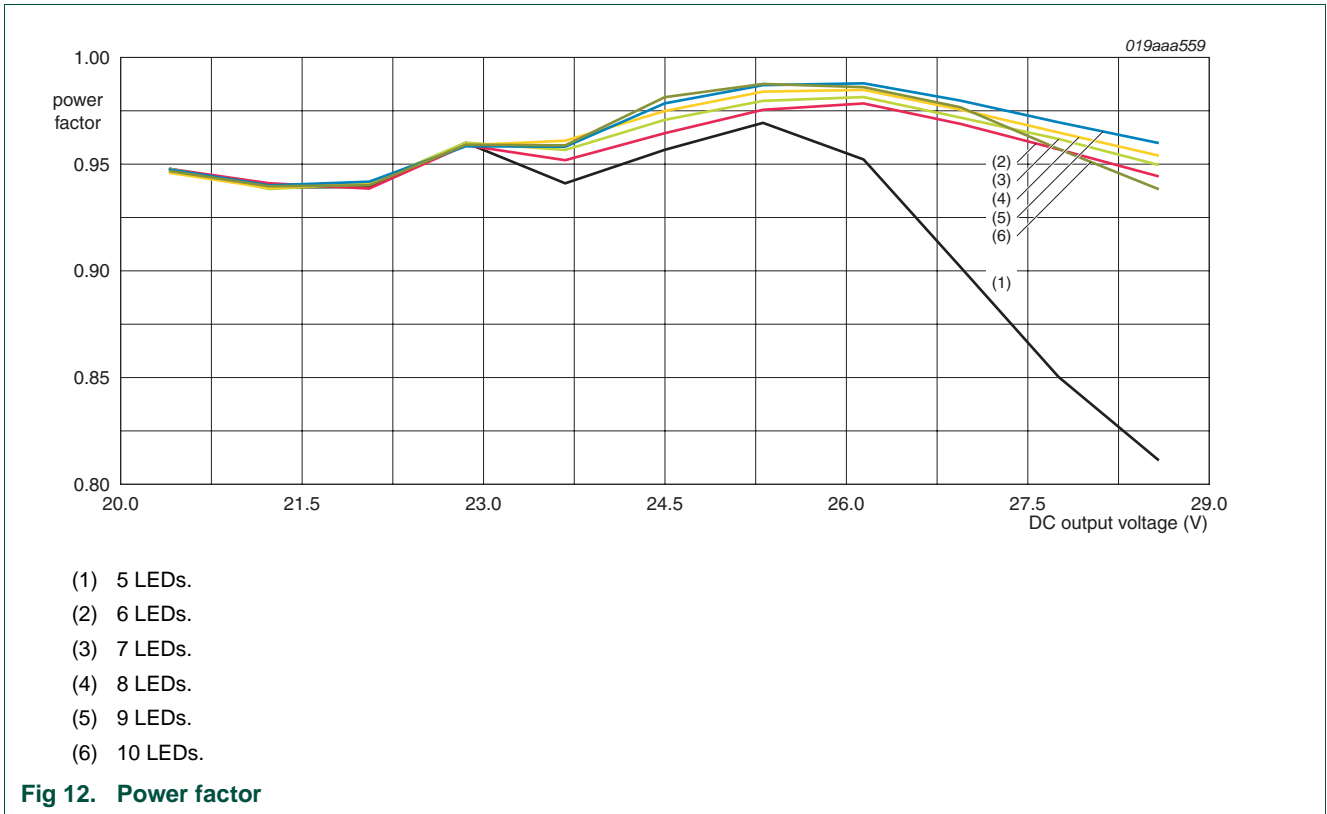

9.5 EMC Pre-compliance

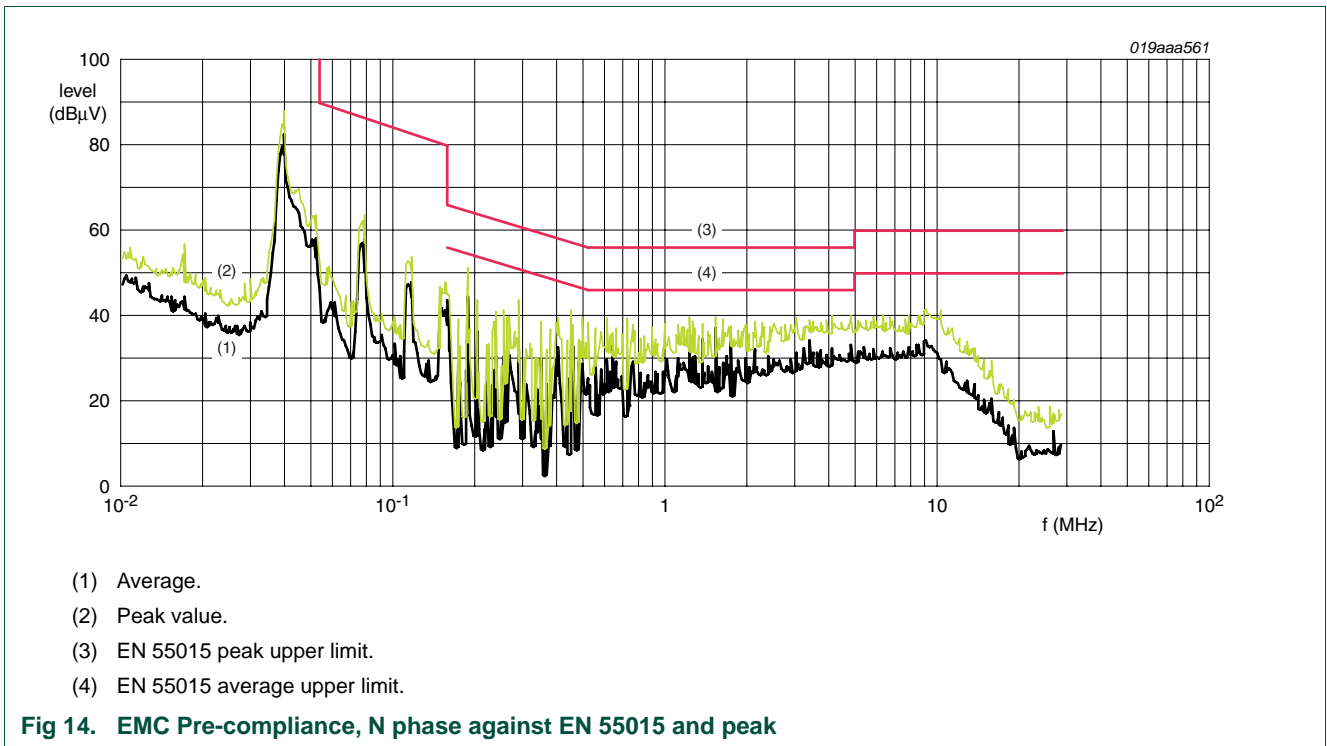
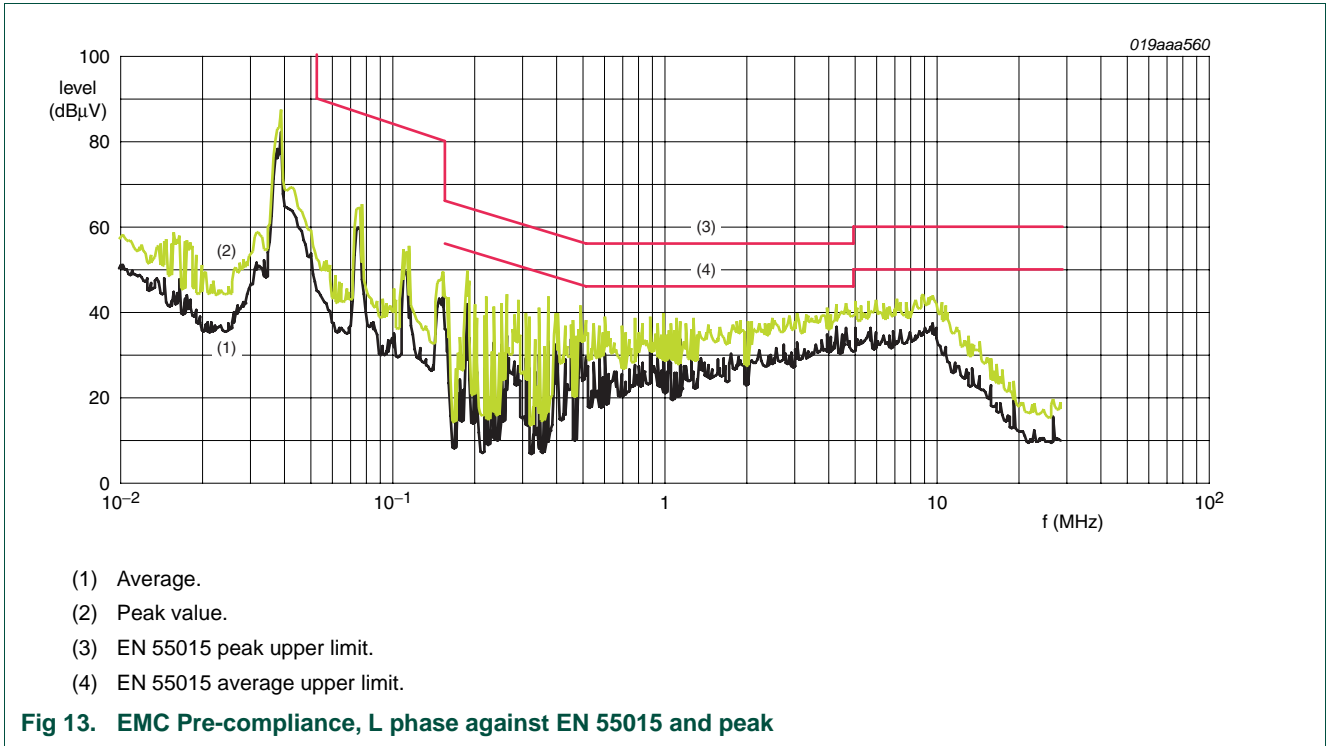

9.6 AC Mains harmonics

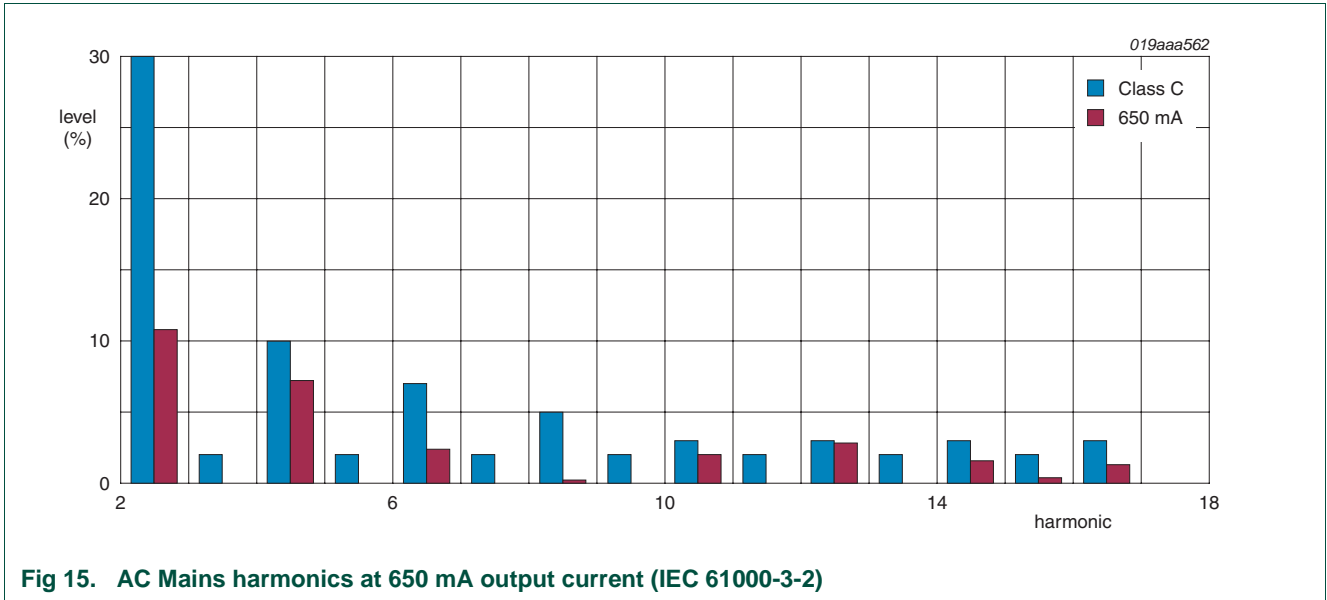

10. Legal information

10.1 Definitions

Draft — The document is a draft version only. The content is still under internal review and subject to formal approval, which may result in modifications or additions. NXP Semiconductors does not give any representations or warranties as to the accuracy or completeness of information included herein and shall have no liability for the consequences of use of such information.

10.2 Disclaimers

Limited warranty and liability — Information in this document is believed to be accurate and reliable. However, NXP Semiconductors does not give any representations or warranties, expressed or implied, as to the accuracy or completeness of such information and shall have no liability for the consequences of use of such information.

In no event shall NXP Semiconductors be liable for any indirect, incidental, punitive, special or consequential damages (including - without limitation - lost profits, lost savings, business interruption, costs related to the removal or replacement of any products or rework charges) whether or not such damages are based on tort (including negligence), warranty, breach of contract or any other legal theory.

Notwithstanding any damages that customer might incur for any reason whatsoever, NXP Semiconductors' aggregate and cumulative liability towards customer for the products described herein shall be limited in accordance with the *Terms and conditions of commercial sale* of NXP Semiconductors.

Right to make changes — NXP Semiconductors reserves the right to make changes to information published in this document, including without limitation specifications and product descriptions, at any time and without notice. This document supersedes and replaces all information supplied prior to the publication hereof.

Suitability for use — NXP Semiconductors products are not designed, authorized or warranted to be suitable for use in life support, life-critical or safety-critical systems or equipment, nor in applications where failure or malfunction of an NXP Semiconductors product can reasonably be expected to result in personal injury, death or severe property or environmental damage. NXP Semiconductors accepts no liability for inclusion and/or use of NXP Semiconductors products in such equipment or applications and therefore such inclusion and/or use is at the customer's own risk.

Applications — Applications that are described herein for any of these products are for illustrative purposes only. NXP Semiconductors makes no representation or warranty that such applications will be suitable for the specified use without further testing or modification.

Customers are responsible for the design and operation of their applications and products using NXP Semiconductors products, and NXP Semiconductors accepts no liability for any assistance with applications or customer product

design. It is customer's sole responsibility to determine whether the NXP Semiconductors product is suitable and fit for the customer's applications and products planned, as well as for the planned application and use of customer's third party customer(s). Customers should provide appropriate design and operating safeguards to minimize the risks associated with their applications and products.

NXP Semiconductors does not accept any liability related to any default, damage, costs or problem which is based on any weakness or default in the customer's applications or products, or the application or use by customer's third party customer(s). Customer is responsible for doing all necessary testing for the customer's applications and products using NXP Semiconductors products in order to avoid a default of the applications and the products or of the application or use by customer's third party customer(s). NXP does not accept any liability in this respect.

Export control — This document as well as the item(s) described herein may be subject to export control regulations. Export might require a prior authorization from national authorities.

Evaluation products — This product is provided on an "as is" and "with all faults" basis for evaluation purposes only. NXP Semiconductors, its affiliates and their suppliers expressly disclaim all warranties, whether express, implied or statutory, including but not limited to the implied warranties of non-infringement, merchantability and fitness for a particular purpose. The entire risk as to the quality, or arising out of the use or performance, of this product remains with customer.

In no event shall NXP Semiconductors, its affiliates or their suppliers be liable to customer for any special, indirect, consequential, punitive or incidental damages (including without limitation damages for loss of business, business interruption, loss of use, loss of data or information, and the like) arising out of the use of or inability to use the product, whether or not based on tort (including negligence), strict liability, breach of contract, breach of warranty or any other theory, even if advised of the possibility of such damages.

Notwithstanding any damages that customer might incur for any reason whatsoever (including without limitation, all damages referenced above and all direct or general damages), the entire liability of NXP Semiconductors, its affiliates and their suppliers and customer's exclusive remedy for all of the foregoing shall be limited to actual damages incurred by customer based on reasonable reliance up to the greater of the amount actually paid by customer for the product or five dollars (US\$5.00). The foregoing limitations, exclusions and disclaimers shall apply to the maximum extent permitted by applicable law, even if any remedy fails of its essential purpose.

10.3 Trademarks

Notice: All referenced brands, product names, service names and trademarks are the property of their respective owners.

11. Contents

1	Introduction	3
2	Specification	4
3	Demo board connections	7
4	Dimmers	8
5	Functional description	9
6	System optimization	12
6.1	Changing output voltage and LED current . . .	12
6.2	Changing the output ripple current	12
6.3	Adapting to high power reverse phase (transistor) dimmers	13
6.4	Changing the output current	13
7	Demo board schematic	14
8	PCB components	15
9	Test results	17
9.1	Input/output stability	17
9.2	Efficiency graphs	18
9.3	Temperature stability	19
9.4	Power factor	19
9.5	EMC Pre-compliance	20
9.6	AC Mains harmonics	21
10	Legal information	22
10.1	Definitions	22
10.2	Disclaimers	22
10.3	Trademarks	22
11	Contents	23

Please be aware that important notices concerning this document and the product(s) described herein, have been included in section 'Legal information'.

© NXP B.V. 2010.

All rights reserved.

For more information, please visit: <http://www.nxp.com>

For sales office addresses, please send an email to: salesaddresses@nxp.com

Date of release: 30 September 2010

Document identifier: UM10417